

FIGURE 1

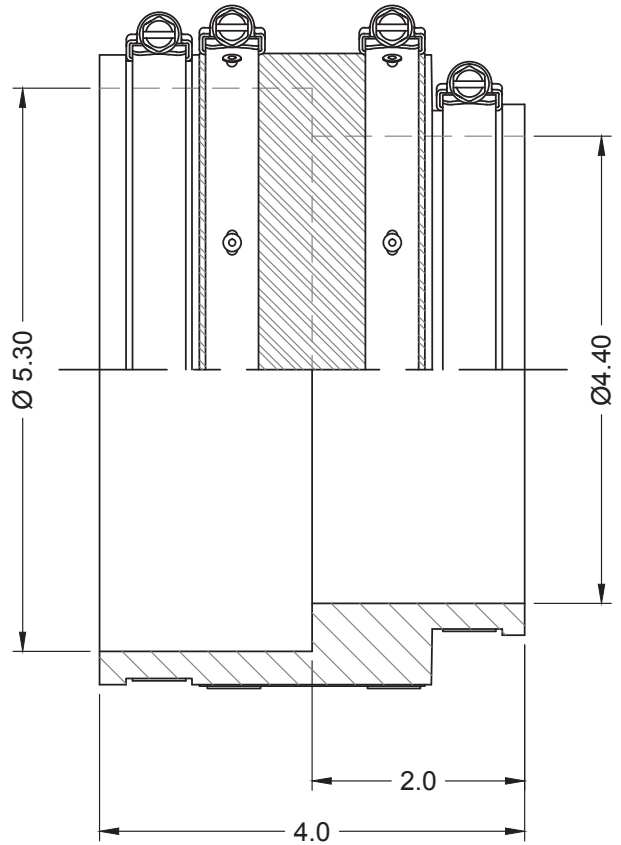

FIGURE 2

PART NO.	FIGURE	COUPLING	REDUCER	A DIAMETER	SHEAR RING	THICKNESS	STRAP
102-44ASR	2	102-44	NONE	4.40	SSASR-96	0.012	SSHC-80,96
102-44ASRP	1	101-44	R02-44P	4.28	SSASR-96	0.012	SSHC-96
102-44ASRi	1	101-44	R02-44i	4.50	SSASR-96	0.012	SSHC-96
102-44ASRB	2	102-44	NONE	4.40	SSASR-96	0.012	SSBC-450,530
102-44ASRBP	1	101-44	R02-44P	4.28	SSASR-96	0.012	SSBC-530
102-44ASRBi	1	101-44	R02-44i	4.50	SSASR-96	0.012	SSBC-530

INDIANA SEAL
A GPK PRODUCTS Company

MATERIAL LIST		
QTY	ITEM	P/N
1	COUPLING	102-44
1	CLAMP	SSHC-80
1	CLAMP	SSHC-96
1	SHEAR RING	SSASR-96

FOR REFERENCE ONLY DIMENSIONS SUBJECT TO CHANGE

TITLE
**AMAZON SHEAR RING COUPLING
4" CLAY x 4" CI / PVC**